



SINGLE POST FULL RISE LIFT

Bear newly designed single post lift is the perfect choice for quickly lifting a vehicle. It can be used in commercial service shops, home garages, or areas where it will take up less space.



30-SP60

SINGLE POST LIFT

Main Features

- ✓ Lifting capacity: 6,000 lbs
- ✓ Max. lifting height: 77 1/8" (1960 mm)
- ✓ Min height: 4 1/8" (105 mm)
- ✓ Self-lubricating UHMW Polyethylene sliders and a self-lubricating bronze bushings.
- ✓ High quality cylinders and power units are manufactured to high standards.
- ✓ Five-years warranty on steel structured components, three-years warranty on hydraulic parts and two-years on electrical components.



The chain protection cover prevents the chain from slipping off.



A manually locking release safety device controls the double locks.



Features screw and insert rubber pads.



Adjustable, portable ramps with free installation.



Arm locking device with easy to release handles.

SPECIFICATIONS

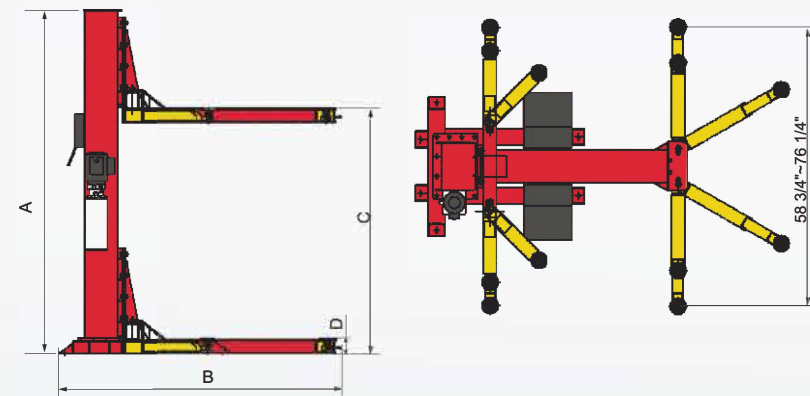

Model	30-SP60	
Lifting Capacity	6,000lbs(2800kg)	
Lifting Time	84S (110V) 32S (220V)	
Overall Height	A	108 7/8"(2766mm)
Overall Width	B	84 1/2"(2146mm)
Lifting Height	C	71 7/8"-77 1/8"(1825mm ~ 1960mm)
Minimum Pad Height	D	4 1/8"(105mm)
Motor	1.0PH, 110V/60Hz, single phase 2.0PH, 220V/60Hz, single phase	
Gross Weight	1,484lbs(673kg)	