



# SINGLE POST PORTABLE LIFT

*Bear portable single post lift rolls smoothly across any flat surface and can be used indoors or outdoors. It's the perfect choice for any commercial service shop that needs to utilize less space.*



30-MP60

## Main Features

- ✓ 6,000lbs capacity, portable single post lift.
- ✓ Max. lifting height: 77 1/8" (1960 mm)
- ✓ Min height: 4 1/8" (105 mm)
- ✓ Self-lubricating UHMW Polyethylene sliders and a self-lubricating bronze bushings.
- ✓ High quality cylinders and power units are manufactured to high quality standards.
- ✓ Five-years warranty on steel structured components, three-years warranty on hydraulic parts and two-years on electrical components.



"Jack Pallet" style device allows the lift to be moved wherever you need it.

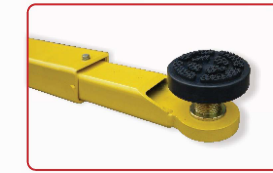

Features insert and screw rubber pads.



The chain protection cover prevents the chain from slipping off.

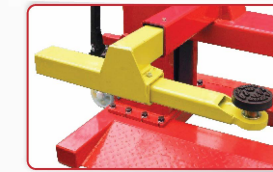

Adjustable arms with two stage positions.

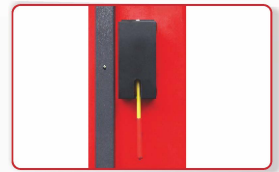

A manual locking safety release device controls the double locks.



Wheels allow the lift to be rolled into different positions



Arm locking device with easy release handles.

## SPECIFICATIONS

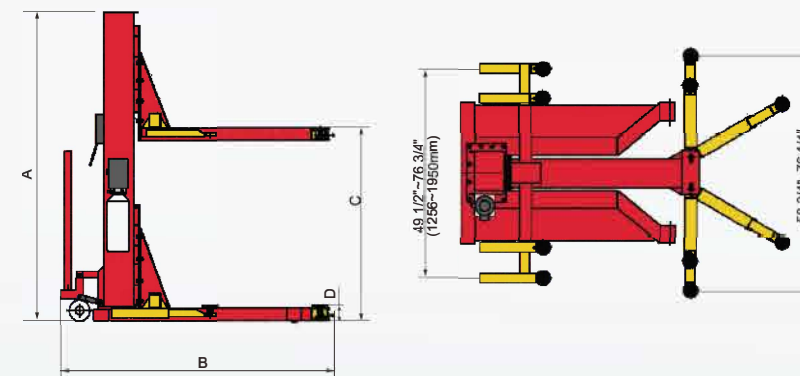

Model	30-MP60	
Lifting Capacity	6,000lbs(2800kg)	
Lifting Time	84S (110V) 32S (220V)	
Overall Height	A	108 7/8"(2766mm)
Overall Width	B	90 3/8"(2295mm)
Lifting Height	C	71 7/8"-77 1/8"(1825mm ~ 1960mm)
Minimum Pad Height	D	4 1/8"(105mm)
Motor	1.0PH,110V/60Hz,single phase 2.0PH,220V/60Hz,single phase	
Gross Weight	1,870lbs(848kg)	